

- You have 2 hours.
- The exam is closed book, closed notes except a one-page crib sheet.
- Please use non-programmable calculators only.
- Mark your answers ON THE EXAM ITSELF. If you are not sure of your answer you may wish to provide a brief explanation. All short answer sections can be successfully answered in a few sentences AT MOST.

First name	
Last name	
SID	
Login	
First and last name of student to your left	
First and last name of student to your right	

For staff use only:

Total	/??
-------	-----

THIS PAGE IS INTENTIONALLY LEFT BLANK

# Q1. [?? pts] Markov Decision Processes

(a) [?? pts] Write out the equations to be used to compute  $Q_i^*$  from  $R, T, V_{i-1}^*, \gamma$  and to compute  $V_i^*$  from  $R, T, Q_i^*, \gamma$ .

$$Q_i^*(s, a) =$$

$$V_i^*(s) =$$

(b) [?? pts] Consider the MDP with transition model and reward function as given in the table below. Assume the discount factor  $\gamma = 1$ , i.e., no discounting. Fill in the values for  $V_0^*, V_1^*, V_2^*, Q_1^*, Q_2^*$  in the graph below.

s	a	s'	T(s,a,s')	R(s,a,s')
A	1	A	0	0
A	1	B	1	0
A	2	A	1	1
A	2	B	0	0
A	3	A	0.5	0
A	3	B	0.5	0

s	a	s'	T(s,a,s')	R(s,a,s')
B	1	A	0.5	10
B	1	B	0.5	0
B	2	A	1	0
B	2	B	0	0
B	3	A	0.5	2
B	3	B	0.5	4

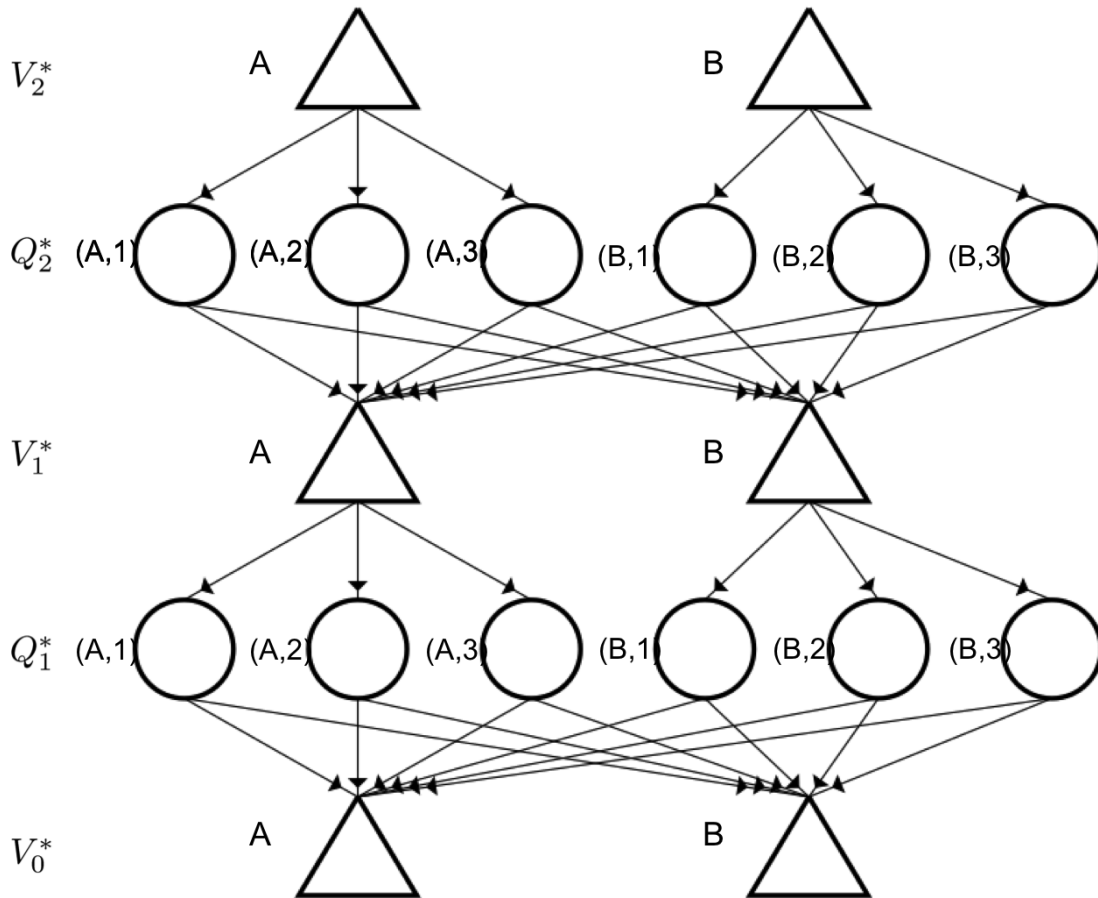

(c) [?? pts] Let  $\pi_i^*(s)$  be the optimal action in state  $s$  with  $i$  time steps to go. Fill in the following tables:

s	$\pi_1^*(s)$
A	
B	

s	$\pi_2^*(s)$
A	
B	

## Q2. [?? pts] MDPs and Utility: Short Questions

Each True/False question is worth 2 points. Leaving a question blank is worth 0 points. **Answering incorrectly is worth -2 points.**

For the questions that are not True/False, answer as concisely as possible (and no points are subtracted for a wrong answer to these).

### (a) Utility.

- (i) [true or false] If an agent has the preference relationship  $(A \succ B) \wedge (B \succ C) \wedge (C \succ A)$  then this agent can be induced to give away all of its money.
- (ii) [true or false] Assume Agent 1 has a utility function  $U_1$  and Agent 2 has a utility function  $U_2$ . If  $U_1 = k_1 U_2 + k_2$  with  $k_1 > 0, k_2 > 0$  then Agent 1 and Agent 2 have the same preferences.

### (b) Insurance. Some useful numbers: $\log(101) \approx 4.6151, \log(71) \approx 4.2627$ .

PacBaby just found a \$100 bill—it is the only thing she owns. Ghosts are nice enough not to kill PacBaby, but when they find PacBaby they will steal all her money. The probability of the ghosts finding PacBaby is 20%. PacBaby's utility function is  $U(x) = \log(1 + x)$  (this is the natural logarithm, i.e.,  $\log e^x = x$ ), where  $x$  is the total monetary value she owns. When PacBaby gets to keep the \$100 (ghosts don't find her) her utility is  $U(\$100) = \log(101)$ . When PacBaby loses the \$100 (per the ghosts taking it from her) her utility is  $U(\$0) = \log(1 + 0) = 0$ .

- (i) [?? pts] What is the expected utility for PacBaby?

- (ii) [?? pts] Pacgressive offers theft insurance: if PacBaby pays an insurance premium of \$30, then they will reimburse PacBaby \$70 if the ghosts steal all her money (after paying \$30 in insurance, she would only have \$70 left). What is the expected utility for PacBaby if she takes insurance? For PacBaby to maximize her expected utility should she take this insurance?

- (iii) [?? pts] In the above scenario, what is the expected monetary value of selling the insurance from Pacgressive's point of view?

### (c) MDPs.

- (i) [true or false] If the only difference between two MDPs is the value of the discount factor then they must have the same optimal policy.
- (ii) [true or false] When using features to represent the Q-function (rather than having a tabular representation) it is possible that Q-learning does not find the optimal Q-function  $Q^*$ .
- (iii) [true or false] For an infinite horizon MDP with a finite number of states and actions and with a discount factor  $\gamma$ , with  $0 < \gamma < 1$ , value iteration is guaranteed to converge.

- (d) [?? pts] Recall that for a deterministic policy  $\pi$  where  $\pi(s)$  is the action to be taken in state  $s$  we have that the value of the policy satisfies the following equations:

$$V^\pi(s) = \sum_{s'} T(s, \pi(s), s') (R(s, \pi(s), s') + \gamma V^\pi(s')).$$

Now assume we have a stochastic policy  $\pi$  where  $\pi(s, a) = P(a|s)$  is equal to the probability of taking action  $a$  when in state  $s$ . Write the equivalent of the above equation for the value of this stochastic policy.

$$V^\pi(s) =$$

### Q3. [?? pts] Bayes' Nets Representation and Probability

Suppose that a patient can have a symptom ( $S$ ) that can be caused by two different diseases ( $A$  and  $B$ ). It is known that the variation of gene  $G$  plays a big role in the manifestation of disease  $A$ . The Bayes' Net and corresponding conditional probability tables for this situation are shown below. For each part, you may leave your answer as an arithmetic expression.

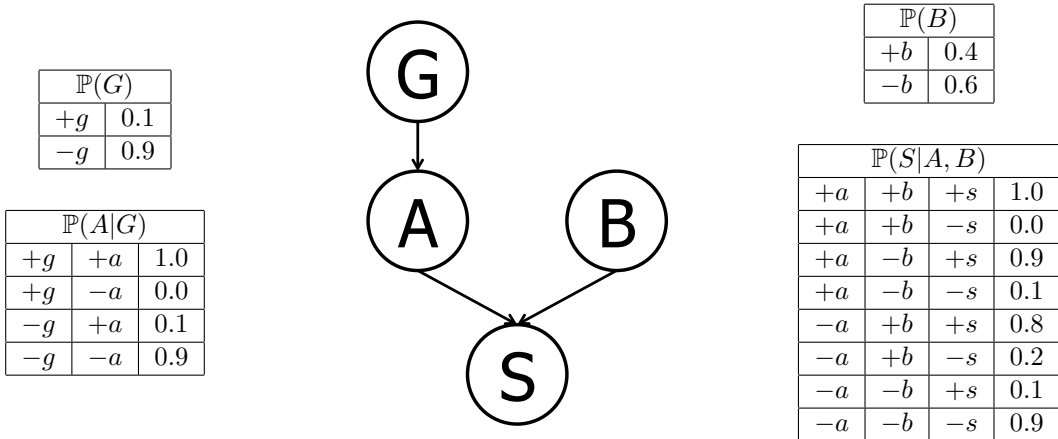

(a) [?? pts] Compute the following entry from the joint distribution:

$$\mathbb{P}(+g, +a, +b, +s) =$$

(b) [?? pts] What is the probability that a patient has disease  $A$ ?

$$\mathbb{P}(+a) =$$

(c) [?? pts] What is the probability that a patient has disease  $A$  given that they have disease  $B$ ?

$$\mathbb{P}(+a | +b) =$$

The figures and table below are identical to the ones on the previous page and are repeated here for your convenience.

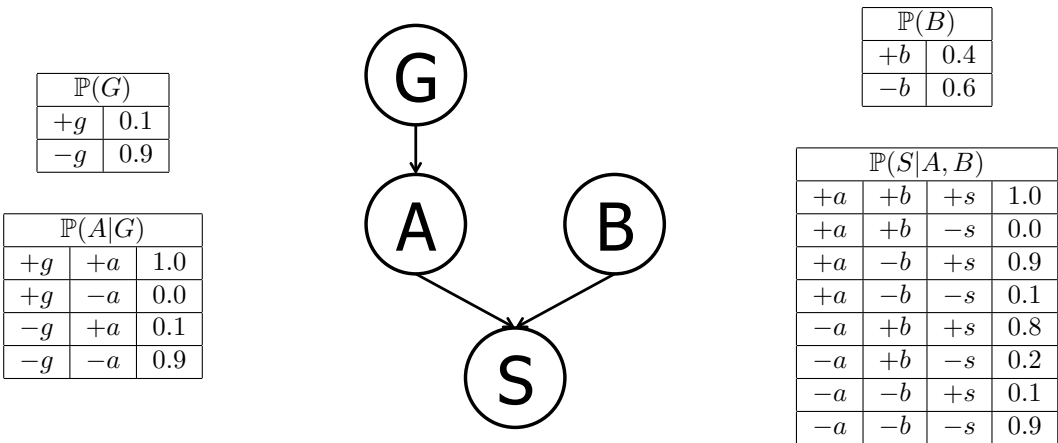

(d) [?? pts] What is the probability that a patient has disease  $A$  given that they have symptom  $S$  and disease  $B$ ?

$$\mathbb{P}(+a | +s, +b) =$$

(e) [?? pts] What is the probability that a patient has the disease carrying gene variation  $G$  given that they have disease  $A$ ?

$$\mathbb{P}(+g | +a) =$$

(f) [?? pts] What is the probability that a patient has the disease carrying gene variation  $G$  given that they have disease  $B$ ?

$$\mathbb{P}(+g | +b) =$$

## Q4. [?? pts] D-Separation

- (a) [?? pts] Based only on the structure of the (new) Bayes' Net given below, circle whether the following conditional independence assertions are guaranteed to be true, guaranteed to be false, or cannot be determined by the structure alone.

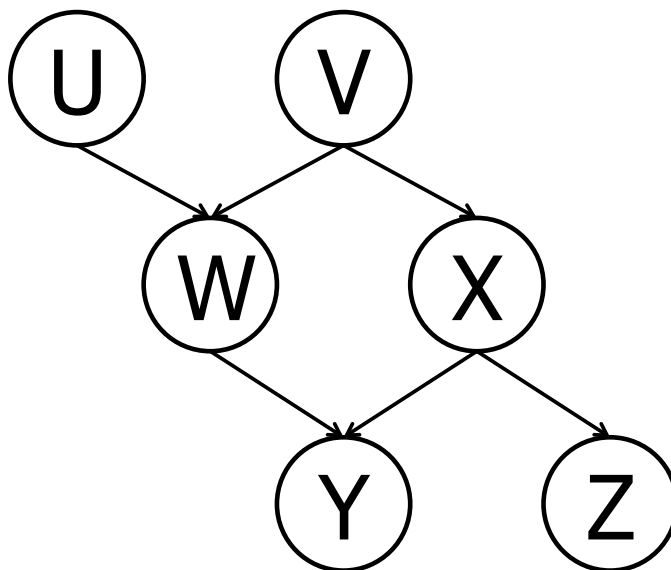

$U \perp\!\!\!\perp V$       Guaranteed true      Cannot be determined      Guaranteed false

$U \perp\!\!\!\perp V \mid W$       Guaranteed true      Cannot be determined      Guaranteed false

$U \perp\!\!\!\perp V \mid Y$       Guaranteed true      Cannot be determined      Guaranteed false

$U \perp\!\!\!\perp Z \mid W$       Guaranteed true      Cannot be determined      Guaranteed false

$U \perp\!\!\!\perp Z \mid V, Y$       Guaranteed true      Cannot be determined      Guaranteed false

$U \perp\!\!\!\perp Z \mid X, W$       Guaranteed true      Cannot be determined      Guaranteed false

$W \perp\!\!\!\perp X \mid Z$       Guaranteed true      Cannot be determined      Guaranteed false

$V \perp\!\!\!\perp Z \mid X$       Guaranteed true      Cannot be determined      Guaranteed false

## Q5. [?? pts] Variable Elimination

- (a) [?? pts] For the Bayes' net below, we are given the query  $P(Z \mid +y)$ . All variables have binary domains. Assume we run variable elimination to compute the answer to this query, with the following variable elimination ordering:  $U, V, W, T, X$ .

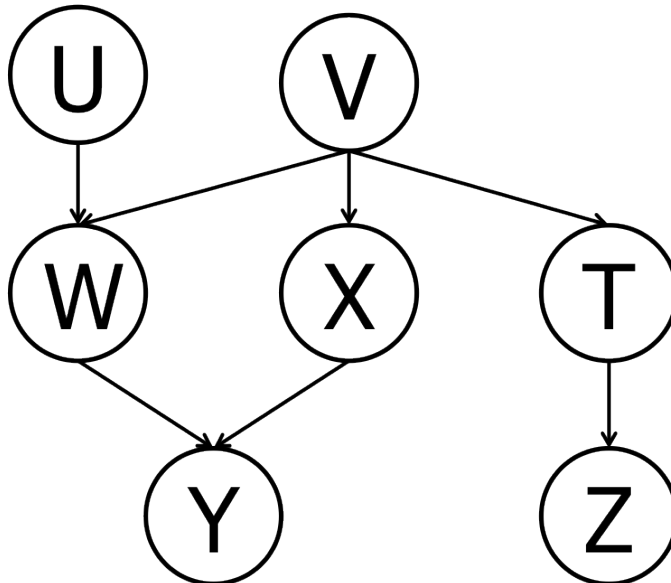

Complete the following description of the factors generated in this process:

After inserting evidence, we have the following factors to start out with:

$$P(U), P(V), P(W|U, V), P(X|V), P(T|V), P(+y|W, X), P(Z|T).$$

When eliminating  $U$  we generate a new factor  $f_1$  as follows:

$$f_1(V, W) = \sum_u P(u)P(W|u, V).$$

This leaves us with the factors:

$$P(V), P(X|V), P(T|V), P(+y|W, X), P(Z|T), f_1(V, W).$$

When eliminating  $V$  we generate a new factor  $f_2$  as follows:

This leaves us with the factors:

When eliminating  $W$  we generate a new factor  $f_3$  as follows:



This leaves us with the factors:

When eliminating  $T$  we generate a new factor  $f_4$  as follows:

This leaves us with the factor:

When eliminating  $X$  we generate a new factor  $f_5$  as follows:

This leaves us with the factor:

- (b) [?? pts] Briefly explain how  $P(Z | +y)$  can be computed from  $f_5$ .
  
- (c) [?? pts] Amongst  $f_1, f_2, \dots, f_5$ , which is the largest factor generated? (Assume all variables have binary domains.) How large is this factor?
  
- (d) [?? pts] Find a variable elimination ordering for the same query, i.e., for  $P(Z | y)$ , for which the maximum size factor generated along the way is smallest. Hint: the maximum size factor generated in your solution should have only 2 variables, for a size of  $2^2 = 4$  table. Fill in the variable elimination ordering and the factors generated into the table below.

Variable Eliminated	Factor Generated

Note: in the naive ordering we used earlier, the first line in this table would have had the following two entries:  $U$ ,  $f_1(V, W)$ .

# Q6. [?? pts] Bayes' Nets Sampling

Assume the following Bayes net, and the corresponding distributions over the variables in the Bayes net:

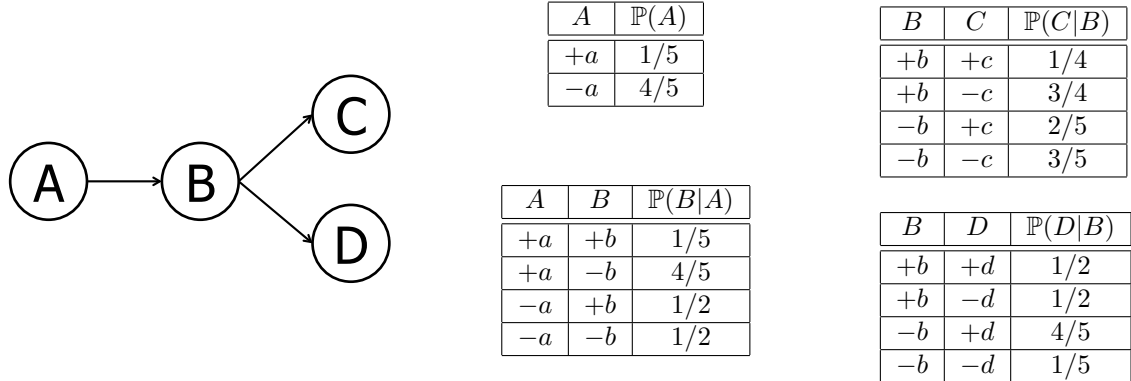

A	$\mathbb{P}(A)$
+a	1/5
-a	4/5

B	C	$\mathbb{P}(C B)$
+b	+c	1/4
+b	-c	3/4
-b	+c	2/5
-b	-c	3/5

A	B	$\mathbb{P}(B A)$
+a	+b	1/5
+a	-b	4/5
-a	+b	1/2
-a	-b	1/2

B	D	$\mathbb{P}(D B)$
+b	+d	1/2
+b	-d	1/2
-b	+d	4/5
-b	-d	1/5

(a) [?? pts] Your task is now to estimate  $\mathbb{P}(+b | -a, -c, -d)$  using rejection sampling. Below are some samples that have been produced by prior sampling (that is, the rejection stage in rejection sampling hasn't happened yet). Cross out the samples that would be rejected by rejection sampling:

- |    |    |    |    |    |    |    |    |
|----|----|----|----|----|----|----|----|
| -a | -b | +c | +d | -a | -b | -c | -d |
| +a | -b | -c | +d | -a | +b | +c | +d |
| -a | -b | +c | -d | +a | -b | -c | -d |

(b) [?? pts] Using those samples, what value would you estimate for  $\mathbb{P}(+b | -a, -c, -d)$  using rejection sampling?

(c) [?? pts] Using the following samples (which were generated using likelihood weighting), estimate  $\mathbb{P}(+b | -a, -c, -d)$  using likelihood weighting, or state why it cannot be computed.

- |    |    |    |    |
|----|----|----|----|
| -a | -b | -c | -d |
| -a | +b | -c | -d |
| -a | -b | -c | -d |